

Short Barrel 3-Wire Prox Sensors Meet IP67

- Thick nickel-plated brass barrel has wrench flats for easy installation
- Solid potted internal circuitry withstands shocks and water washdown to IP67
- High visibility indicator
- Miniature and standard sizes



Ordering Information

■ PREWIRED MINIATURE SENSORS

Type	Size	Sensing distance	Output configuration	Part number	
				NO	NC
Shielded 	4 mm dia.	0.8 mm	NPN	E2E-CR8C1	E2E-CR8C2
			PNP	E2E-CR8B1	E2E-CR8B2
	M5	1 mm	NPN	E2E-X1C1	E2E-X1C2
			PNP	E2E-X1B1	E2E-X1B2
	5.4 mm dia.	1 mm	NPN	E2E-C1C1	E2E-C1C2
			PNP	E2E-C1B1	E2E-C1B2

■ PREWIRED SHIELDED STANDARD SENSORS

Type	Size	Sensing distance	Output configuration	Part number	
				NO	NC
Shielded 	M8	1.5 mm	NPN	E2E-X1R5E1	E2E-X1R5E2
			PNP	E2E-X1R5F1	E2E-X1R5F2
	M12	2 mm	NPN	E2E-X2E1	E2E-X2E2
			PNP	E2E-X2F1	E2E-X2F2
	M18	5 mm	NPN	E2E-X5E1	E2E-X5E2
			PNP	E2E-X5F1	E2E-X5F2
	M30	10 mm	NPN	E2E-X10E1	E2E-X10E2
			PNP	E2E-X10F1	E2E-X10F2

Note 1. A different oscillating frequency is available. Add a "5" to the part number (e.g., E2E-X5E15).

2. E2E sensors with robot cable are available. Add a "R" to the part number (e.g., E2E-X5E1-R).



■ PREWIRED UNSHIELDED STANDARD SENSORS

Type	Size	Sensing distance	Output configuration	Part number	
				NO	NC
	M8	2 mm	NPN	E2E-X2ME1	E2E-X2ME2
			PNP	E2E-X2MF1	E2E-X2MF2
	M12	5 mm	NPN	E2E-X5ME1	E2E-X5ME2
			PNP	E2E-X5MF1	E2E-X5MF2
	M18	10 mm	NPN	E2E-X10ME1□	E2E-X10ME2□
			PNP	E2E-X10MF1□	E2E-X10MF2□
	M30	18 mm	NPN	E2E-X18ME1	E2E-X18ME2□
			PNP	E2E-X18MF1□	E2E-X18MF2□

Note: 1. A different oscillating frequency is available. Add a "5" to the part number (e.g. E2E-X5E15).



2. E2E sensors with robotic cable are available. Add a "R" to the part number (e.g. E2E-X5E1-R).

■ SENSORS WITH BUILT-IN M12 MICROCHANGE® CONNECTOR

Type	Size	Sensing distance	Output configuration	Part number	
				NO	NC
	M8	1.5 mm	NPN	E2E-X1R5E1-M1	E2E-X1R5E2-M1
			PNP	E2E-X1R5F1-M1	E2E-X1R5F2-M1
	M12	2 mm	NPN	E2E-X2E1-M1	E2E-X2E2-M1
			PNP	E2E-X2F1-M1	E2E-X2F2-M1□
	M18	5 mm	NPN	E2E-X5E1-M1	E2E-X5E2-M1
			PNP	E2E-X5F1-M1	E2E-X5F2-M1□
	M30	10 mm	NPN	E2E-X10E1-M1	E2E-X10E2-M1□
			PNP	E2E-X10F1-M1□	E2E-X10F2-M1
	M8	2 mm	NPN	E2E-X2ME1-M1□	E2E-X2ME2-M1
			PNP	E2E-X2MF1-M1□	E2E-X2MF2-M1□
	M12	5 mm	NPN	E2E-X5ME1-M1	E2E-X5ME2-M1□
			PNP	E2E-X5MF1-M1	E2E-X5MF2-M1□
	M18	10 mm	NPN	E2E-X10ME1-M1□	E2E-X10ME2-M1□
			PNP	E2E-X10MF1-M1	E2E-X10MF2-M1
	M30	18 mm	NPN	E2E-X18ME1-M1□	E2E-X18ME2-M1□
			PNP	E2E-X18MF1-M1	E2E-X18MF2-M1□

Note: Connector cordsets: For MicroChange® models, use OMRON Y96E-4□D□.

■ SENSORS WITH BUILT-IN M8 NANOCHANGE® CONNECTOR

Type	Size	Sensing distance	Output configuration	Part number	
				NO	NC
	M8	1.5 mm	NPN	E2E-X1R5E1-M3	E2E-X1R5E2-M3
			PNP	E2E-X1R5F1-M3	E2E-X1R5F2-M3
	M8	2 mm	NPN	E2E-X2ME1-M3	E2E-X2ME2-M3
			PNP	E2E-X2MF1-M3	E2E-X2MF2-M3

Note: Connector cordsets: For NanoChange® models, use OMRON X3SF-M42□-40□-R or Brad Harrison equivalent.

■ ACCESSORIES

Description		Part number
Mounting brackets	Fits M8 size sensors	Y92E-B8
	Fits M12 size sensors	Y92E-B12
	Fits M18 size sensors	Y92E-B18
	Fits M30 size sensors	Y92E-B30
Silicone rubber covers for shielded sensors	Fits M12 size sensors	Y92E-E12-2
	Fits M18 size sensors	Y92E-E18-2
	Fits M30 size sensors	Y92E-E30-2

■ REPLACEMENT PARTS

Description		Part number
Mounting hardware including one pair of metal nuts and one washer	Fits M5 size sensors	M5-MHWS
	Fits M8 size sensors	M8-MHWS
	Fits M12 size sensors	M12-MHWS
	Fits M18 size sensors	M18-MHWS
	Fits M30 size sensors	M30-MHWS

Specifications

■ MINIATURE SENSORS

Part number		E2E-CR8□□	E2E-X1□□	E2E-C1□□
Size		4 mm (0.16 in) dia.	M5	5.5 mm (0.21 in) dia.
Type		Shielded		
Sensing distance		0.8 mm (0.03 in) ± 15%	1 mm (0.04 in) ± 15%	
Supply voltage		10 to 30 VDC, 10% max. permissible ripple peak to peak		
Current consumption		17 mA max.		
Sensing object		Magnetic metals		
Setting distance		0 to 0.5 mm (0 to 0.02 in)	0 to 7 mm (0 to 0.03 in)	
Standard object (mild steel, L x W x H)		5 x 5 x 1 mm (0.2 x 0.2 x 0.04 in)		8 x 8 x 1 mm (0.3 x 0.3 x 0.04 in)
Differential travel		15% max. of effective distance		
Response frequency		3 kHz		
Control output	Operation	C1 models: NPN-NO open collector C2 models: NPN-NC open collector B1 models: PNP-NO open collector B1 models: PNP-NC open collector		
	Max. load	100 mA switching capacity		
	Max. on-state voltage drop	2 VDC		
Circuit protection		DC power supply reverse polarity		
Indicators		Operation indicator (red LED)		
Ambient temperature	Operating	-25°C to 70°C (-13°F to 158°F) with no icing		
Ambient humidity	Operating	35% to 95%		
Vibration resistance		10 to 55 Hz, 1.5 mm (0.06 in) double amplitude		
Shock resistance		Approx. 50 G's		
Enclosure rating	UL	—		
	NEMA	1, 3, 4, 6, 12, 13		
	IEC 144	IP67		
Weight with cable		Approx. 30 g (1.1 oz.)		
Materials	Housing	Stainless steel	Nickel-plated brass	Nickel-plated brass
	Sensing face	Plastic PBT		
	Cable sheath	Polyvinyl chloride		

E2E-X2E□/F□-N

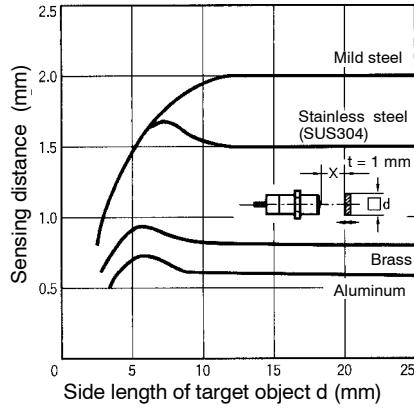

E2E-X5E□/F□-N

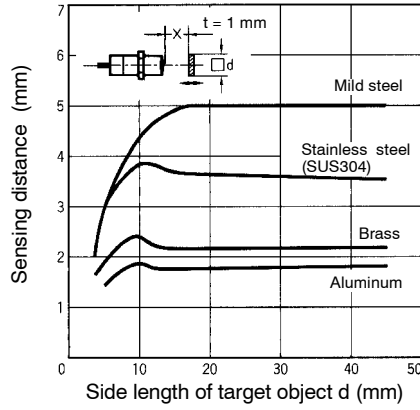

E2E-X10E□/F□-N

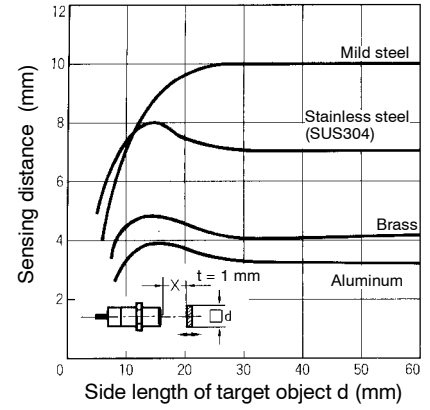

E2E-X2ME□/F□-N

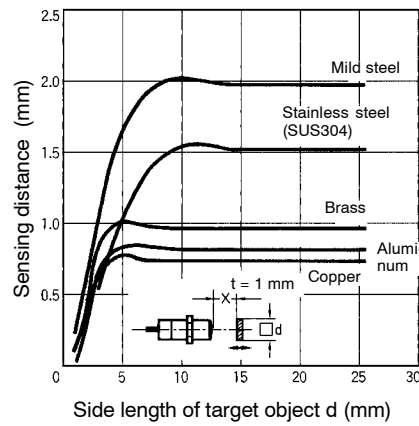

E2E-X5ME□/F□-N

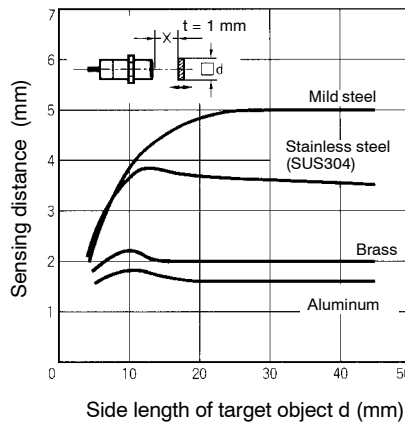

E2E-X10ME□/F□-N

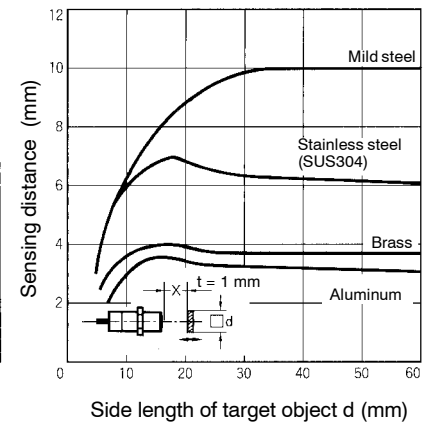

E2E-X18ME□/F□-N
E2E-X18MY□-N

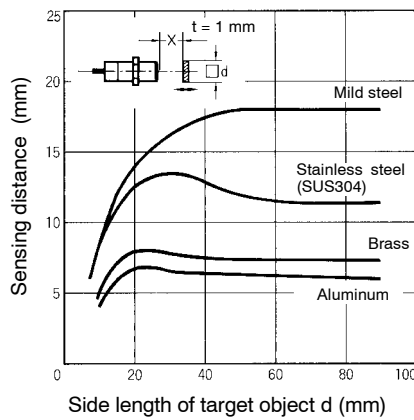

Dimensions

■ DRAWING LOCATOR

Type			Part number	Figure number
Prewired	Shielded	4 mm dia.	E2E-CR8□	1
		M5	E2E-X1□	2
		5.4 mm dia.	E2E-C1□	3
		M8	E2E-X1R5E□/F□-N	4
		M12	E2E-X2E□/F□-N	6
		M18	E2E-X5E□/F□-N	8
		M30	E2E-X10E□/F□-N	10
Prewired	Unshielded	M8	E2E-X2ME□/F□-N	5
		M12	E2E-X5ME□/F□-N	7
		M18	E2E-X10ME□/F□-N	9
		M30	E2E-X18ME□/F□-N	11
4-pin connector (M12)	Shielded	M8	E2E-XR5ME□-M1/F□-M1-N	12
		M12	E2E-X2ME□-M1/F□-M1-N	14
		M18	E2E-X5ME□-M1/F□-M1-N	16
		M30	E2E-X10ME□-M1/F□-M1-N	18
	Unshielded	M8	E2E-X2ME□-M1/F□-M1-N	13
		M12	E2E0-X5ME□-M1/F□-M1-N	15
		M18	E2E-X10ME□-M1/F□-M1-N	17
		M30	E2E-X18ME□-M1/F□-M1-N	19
M8 connector	Shielded	M8	E2E-X1R5E□-M3/□F-M3-N	20
	Unshielded		E2E-X2ME□-M3/□F-M3-N	21

Unit: mm (inch)

■ SENSORS

Miniature Shielded DC Types

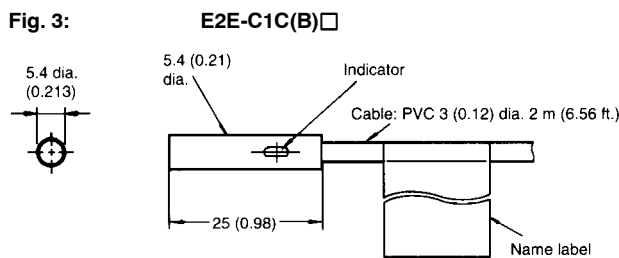
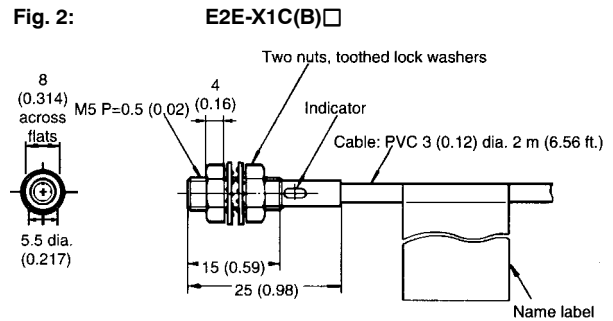
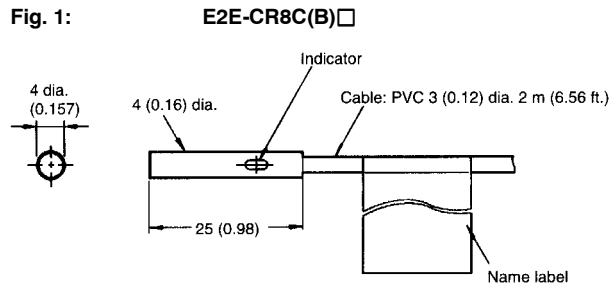

Prewired Models (Shielded)

Fig. 4:

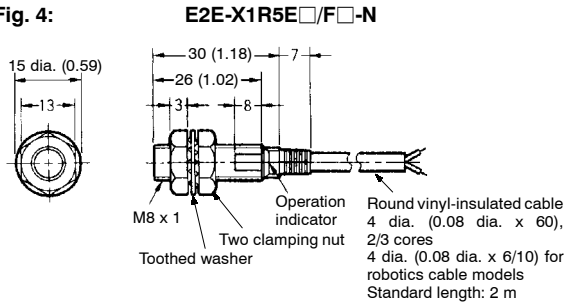

Prewired Models (Unshielded)

Fig. 5:

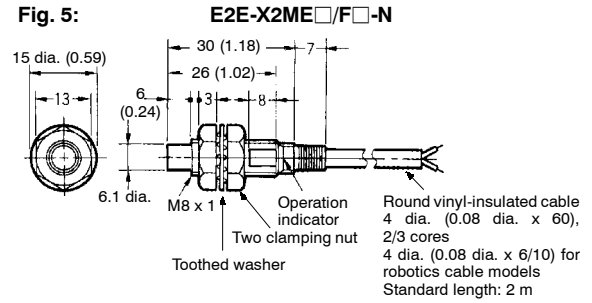

Fig. 6:

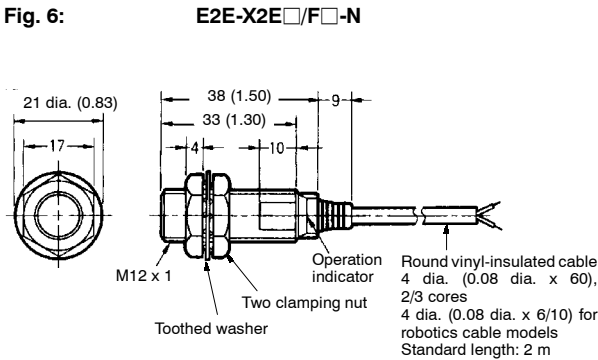

Fig.7:

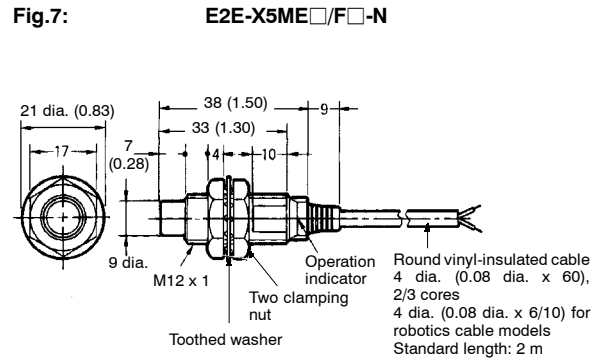

Fig. 8:

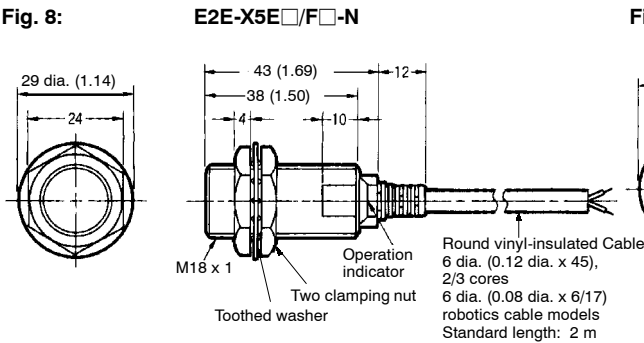

Fig. 9:

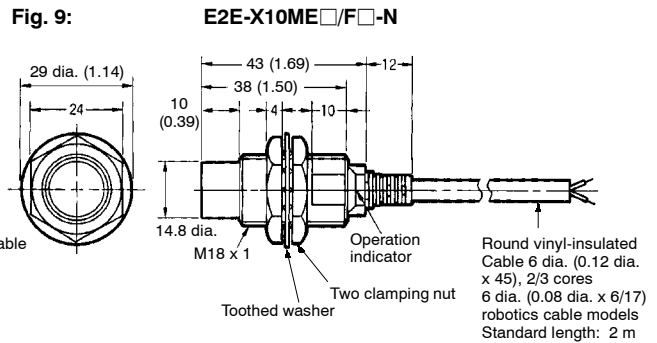

Fig. 10:

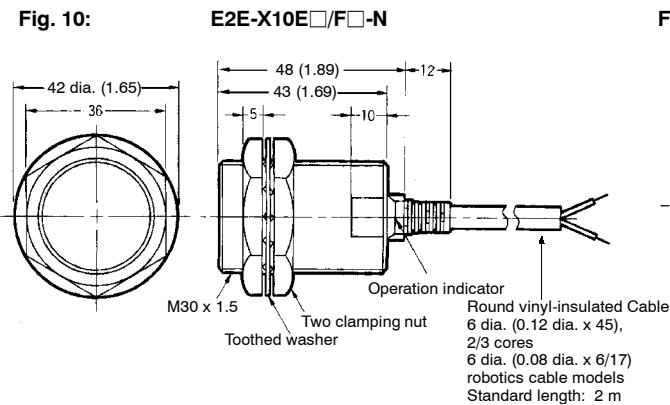
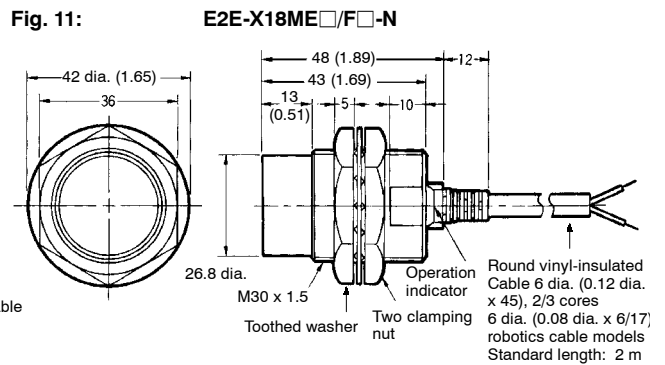

Fig. 11:



**Connector Models
(Shielded)**

Fig. 12: E2E-X1R5E□-M1/F□-M1-N

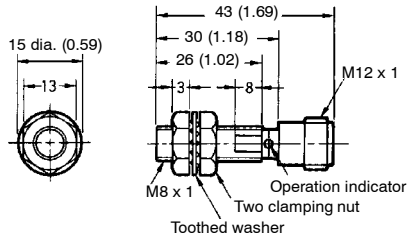

Fig. 14: E2E-X2E□-M1/F□-M1-N

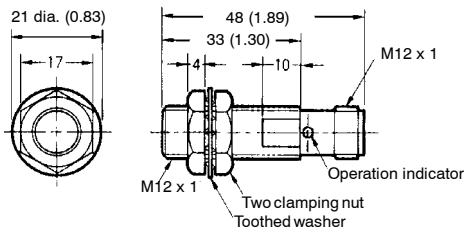

Fig. 16: E2E-X5E□-M1/F□-M1-N

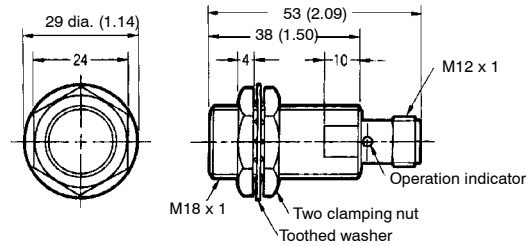
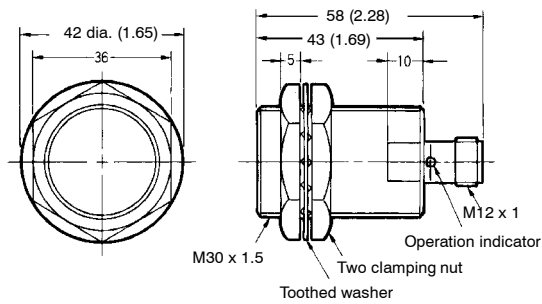

Fig. 18: E2E-X10E□-M1/F□-M1-N



**Connector Models
(Unshielded)**

Fig. 13: E2E-X2ME□-M1/F□-M1-N

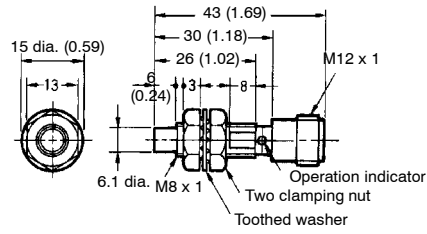

Fig. 15: E2E-X5ME□-M1/F□-M1-N

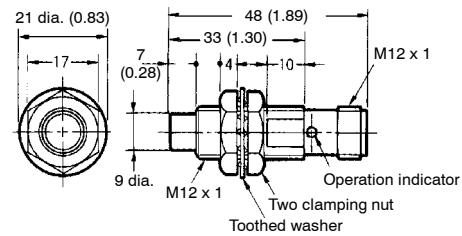

Fig. 17: E2E-X10ME□-M1/F□-M1-N

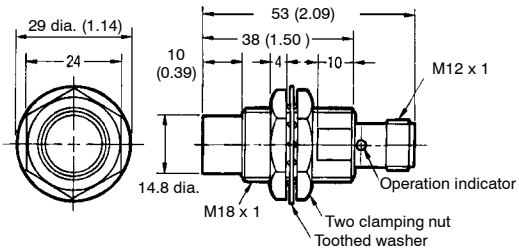
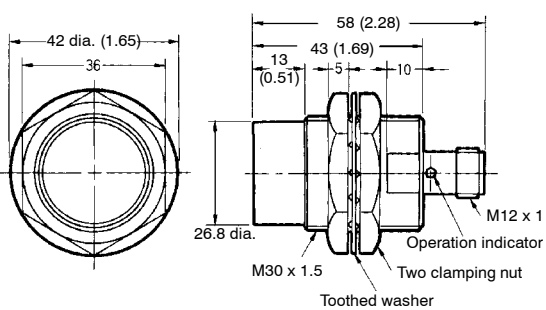
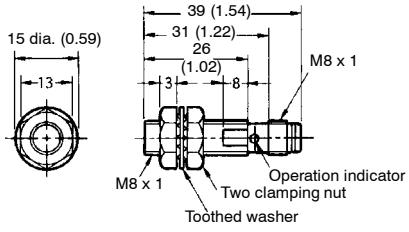

Fig. 19: E2E-X18ME□-M1/F□-M1-N



M8 Connector Models (Shielded)

Fig. 20: E2E-X1R5E□-M3/F□-M3-N



M8 Connector Models (Unshielded)

Fig. 21: E2E-X2ME□-M3/F□-M3-N

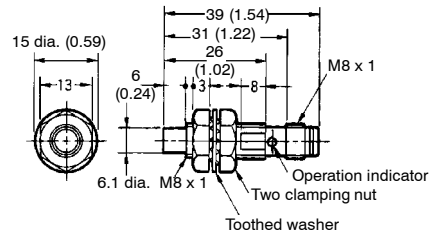

Mounting Holes

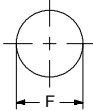

Dimensions	4 dia.	M5	5.4 dia.	M8	M12	M18	M30
F (mm)	4.2 ^{+0.5/0} dia.	5.5 ^{+0.5/0} dia.	5.7 ^{+0.5/0} dia.	8.5 ^{+0.5/0} dia.	12.5 ^{+0.5/0} dia.	18.5 ^{+0.5/0} dia.	30.5 ^{+0.5/0} dia.

Connection

■ PIN ARRANGEMENT

E2E-X□E□-M1

Connector	Output configuration	Applicable models	Pin arrangement
M12 Micro Change®	NO	E2E-X□E1-M1-N	<p>Note: Terminal 2 is not used.</p>
		E2E-X□F1-M1-N	<p>Note: Terminal 2 is not used.</p>
	NC	E2E-X□E2-M1-N	<p>Note: Terminal 4 is not used.</p>
		E2E-X□F2-M1-N	<p>Note: Terminal 4 is not used.</p>

(This table continues on the next page.)

Connector	Output configuration	Applicable models	Pin arrangement
M8 Nano Change®	NO	E2E-X□E1-M3-N	<p>Note: Terminal 2 is not used.</p>
		E2E-X□F1-M3-N	<p>Note: Terminal 2 is not used.</p>
	NC	E2E-X□E2-M3-N	<p>Note: Terminal 4 is not used.</p>
		E2E-X□F2-M3-N	<p>Note: Terminal 4 is not used.</p>

Installation

■ MOUNTING

Do not tighten the nut with excessive force. A washer must be used with the nut.

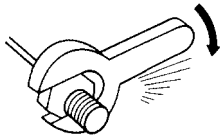

Shielded Model

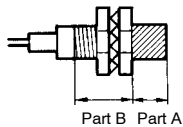

Unshielded Model

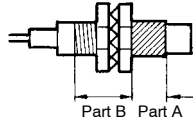

Note: The table above right shows the tightening torques for part A and part B nuts. In the previous examples, the nut is on the sensor head side (part B) and hence the tightening torque for part B applies. If this nut is in part A, the tightening torque for part A applies instead.

Type	Part A		Part B
	Length	Torque	Torque
M5	1 N • m (10 kgf • cm)		
M8	Shielded	9 mm	9 N • m (90 kgf • cm)
	Unshielded	3 mm	12 N • m (120 kgf • cm)
M12	30 N • m (310 kgf • cm)		
M18	70 N • m (710 kgf • cm)		
M30	180 N • m (1,800 kgf • cm)		

Refer to the following to mount the E2E-CR8 and E2E-C1 non-screw models.

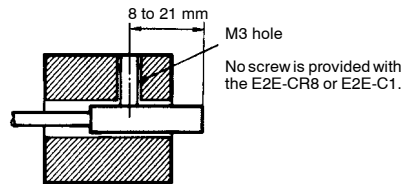

Tighten the screw to a torque of 0.20 N • m (2 kgf • cm) maximum to secure the E2E-CR8 and a torque of 0.39 N • m (4 kgf • cm) maximum to secure the E2E-C1.

■ EFFECTS OF SURROUNDING METAL

When mounting the E2E within a metal panel, ensure that the clearances given in the following table are maintained. Failure to maintain these distances may cause deterioration in the performance of the sensor.

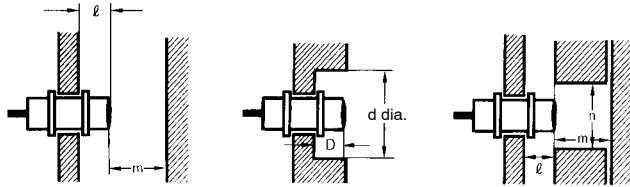

Type	Dimension	4 mm dia.	M5	5.4 mm dia.	M8	M12	M18	M30	
E2ECR8□ E2E-X1□ E2E-C1□ E2E-X□E□-N E2E-X□F□-N DC 3-wire	Shielded	ℓ	0 mm	0 mm	0 mm	0 mm	0 mm	0 mm	
		d	4 mm	5 mm	5.4 mm	8 mm	12 mm	18 mm	30 mm
		D	0 mm	0 mm	0 mm	0 mm	0 mm	0 mm	0 mm
		m	2.9 mm	3 mm	3 mm	4.5 mm	8 mm	20 mm	40 mm
		n	6 mm	8 mm	8 mm	12 mm	18 mm	27 mm	45 mm
	Unshielded	ℓ	—	—	—	6 mm	15 mm	22 mm	30 mm
		d	—	—	—	24 mm	40 mm	55 mm	90 mm
		D	—	—	—	6 mm	15 mm	22 mm	30 mm
		m	—	—	—	8 mm	20 mm	40 mm	70 mm
		n	—	—	—	24 mm	36 mm	54 mm	90 mm

■ MUTUAL INTERFERENCE

When installing two or more Sensors face to face or side by side, ensure that the minimum distances given in the following table are maintained.

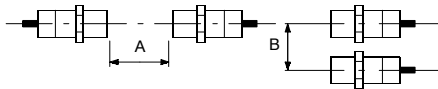

Type	Dimension	4 mm dia.	M5	5.4 mm dia.	M8	M12	M18	M30	
E2ECR8□ E2E-X1□ E2E-C1□ E2E-X□E□-N E2E-X□F□-N DC 3-wire	Shielded	A	20 mm	20 mm	20 mm	20 mm	30 (20) mm	50 (30) mm	100 (50) mm
		B	15 mm	15 mm	15 mm	15 mm	20 (12) mm	35 (18) mm	70 (35) mm
	Unshielded	A	—	—	—	80 mm	120 (60) mm	200 (100) mm	300 (100) mm
		B	—	—	—	60 mm	100 (50) mm	110 (60) mm	200 (100) mm

Note: The figures in parentheses refer to Sensors operating at different frequencies.

Precautions

■ INSTALLATION

Power Reset Time

The Proximity Sensor is ready to operate within 100 ms after power is supplied. If power supplies are connected to the Proximity Sensor and load respectively, be sure to supply power to the Proximity Sensor before supplying power to the load.

Power OFF

The Proximity Sensor may output a pulse signal when it is turned off. You must turn off the load before turning off the Proximity Sensor.

Power Supply Transformer

When using a DC power supply, make sure that the DC power supply has an insulated transformer. Do not use a DC power supply with an auto-transformer.

Sensing Object

Metal Coating

The sensing distances of the Proximity Sensor vary with the metal coating on sensing objects.

■ WIRING

High-tension Lines

Wiring through Metal Conduit

If there is a power or high-tension line near the cable of the Proximity Sensor, wire the cable through an independent metal conduit to prevent against Proximity Sensor damage or malfunctioning.

Cable Tractive Force

Do not pull cable with the tractive forces exceeding the following.

Diameter	Tractive force
4 mm dia. max.	30 N max.
4 mm dia. min.	50 N max.

■ MOUNTING

The Proximity Sensor must not be subjected to excessive shock with a hammer when it is installed, or the Proximity Sensor may be damaged or lose its water-resistance.

■ ENVIRONMENT

Water Resistance

Do not use the Proximity Sensor underwater, outdoors, or in the rain.

Operating Environment

Be sure to use the Proximity Sensor within its operating ambient temperature range and do not use the Proximity Sensor outdoors so that its reliability and life expectancy can be maintained. Although the Proximity Sensor is water resistant, a cover to protect the Proximity Sensor from water or water-soluble machining oil is recommended so that its reliability and life expectancy can be maintained. Do not use the Proximity Sensor in an environment with chemical gas (e.g., strong alkaline or acid gasses including nitric, chromic, and concentrated sulfuric acid gasses).

NOTE: DIMENSIONS SHOWN ARE IN MILLIMETERS. To convert millimeters to inches divide by 25.4.

OMRON[®]

OMRON ELECTRONICS LLC

One East Commerce Drive
Schaumburg, IL 60173

1-800-55-OMRON

OMRON ON-LINE

Global - <http://www.omron.com>
USA - <http://www.omron.com/oei>
Canada - <http://www.omron.com/oci>

OMRON CANADA, INC.

885 Milner Avenue
Scarborough, Ontario M1B 5V8

416-286-6465